



Panel Discussion

Judicial Symposium on Intellectual Property 2024

October 24, 2024



Agenda

- I. Presentations from Judges**
- II. Reviewing Mock Trials**
- III. Recent Trends: from Attorney's Viewpoint**
- IV. Wrap Up**



Agenda

- I. Presentations from Judges**
- II. Reviewing Mock Trials**
- III. Recent Trends: from Attorney's Viewpoint**
- IV. Wrap Up**



Part I: Presentations from Judges

- i. Remark: Presiding Judge Shimizu (Japan)**
- ii. Dr. Grabinski (UPC)**
- iii. Mr. Justice Mellor (UK)**
- iv. Federal Judge Choe-Groves (USA)**



Part I: Presentations from Judges

- i. Remark: Presiding Judge Shimizu (Japan)
- ii. **Dr. Grabinski (UPC)**
- iii. Mr. Justice Mellor (UK)
- iv. Federal Judge Choe-Groves (USA)



Opening presentation

Dr Klaus Grabinski, President of the UPC Court of Appeal

Judicial Symposium on Intellectual Property (JSIP) 2024, Tokyo, 24 October 2024

All written and said is my personal view and not a communication of the UPC Court of Appeal.

I. Career

- Study of law at the Universities of Trier, Geneva and Cologne
- Award of doctorate of law at Trier University in 1991
- Legal traineeship, 1989-1992
- Judge at the Düsseldorf Regional Court, 1992-1997
- Law clerk at the Federal Court of Justice, 1997-2000
- Judge at the Düsseldorf Higher Regional Court, 2000-2001
- Presiding Judge at the Düsseldorf Regional Court, 2001-2009
- Judge at the Federal Court of Justice, 2009-2022 (Vice Presiding Judge, 2020-2022)
- President of the UPC Court of Appeal and Chairman of the UPC Presidium since 2022

II. Characteristics of the Unified Patent Court (UPC)

Characteristics of the Unified Patent Court (UPC)

The Unified Patent Court

- is a court common to several (currently 18) EU Member States,

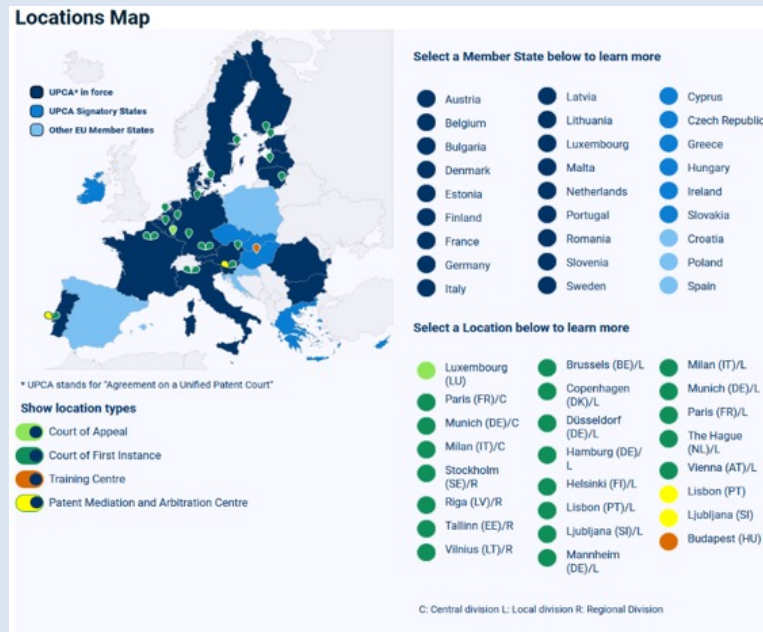

- UPC Agreement in force.
- Signatory State of the UPC Agreement.
- EU Member State that has neither signed nor ratified the UPC Agreement.

The Unified Patent Court

- is a specialist court that
- has jurisdiction on the validity and infringements of
 - European Patents with Unitary Effect (Unitary Patents) and
 - European Patents (Bundle Patents)
 - that have not been opted-out.

The Unified Patent Court

- comprises a Court of First Instance with a Central Division, Local and Regional Divisions, a Court of Appeal and a Registry.

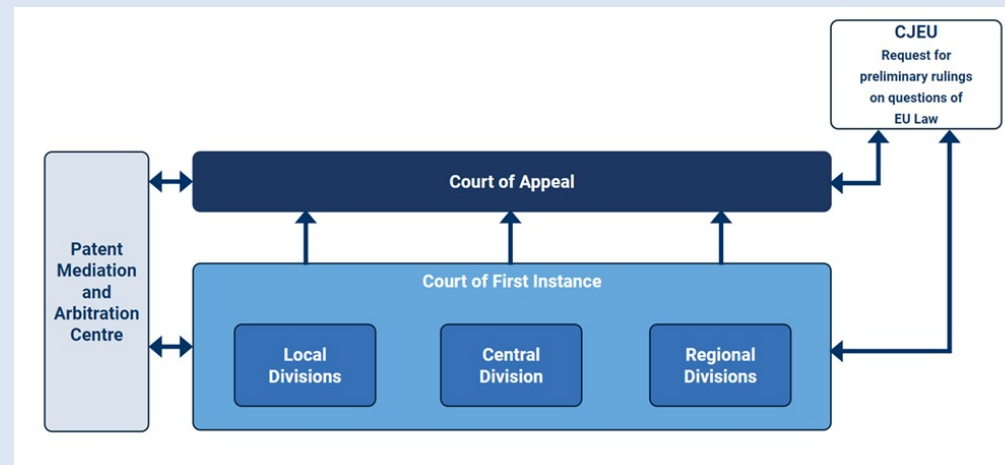

The Unified Patent Court

- decides by panels of legally qualified judges (LQJ) and (in most cases) technically qualified judges from different UPC Member States

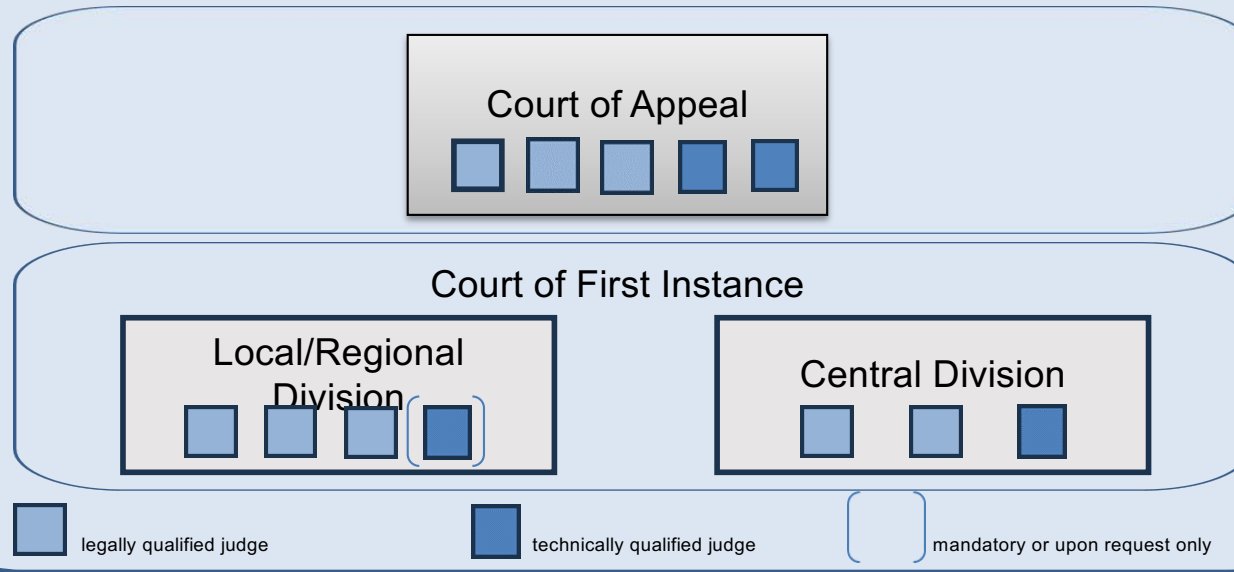

Proceedings before the Unified Patent Court consist of

- a written procedure
 - front loading
 - strict deadlines
- an interim procedure
 - aims at preparing the oral procedure and explore possibilities for a settlement of the case
- an oral procedure
 - endeavour to have it taken place within 1 year whilst recognising that complex actions may require more time.

The language of proceedings before the Unified Patent Court

- Local Division
 - Official language(s) of the State hosting the Local Division or
 - English
- Nordic Baltic Regional Division
 - English
- Central Division
 - Language of the patent (English, German or French)
- Court of Appeal
 - Language of the proceedings of the first instance

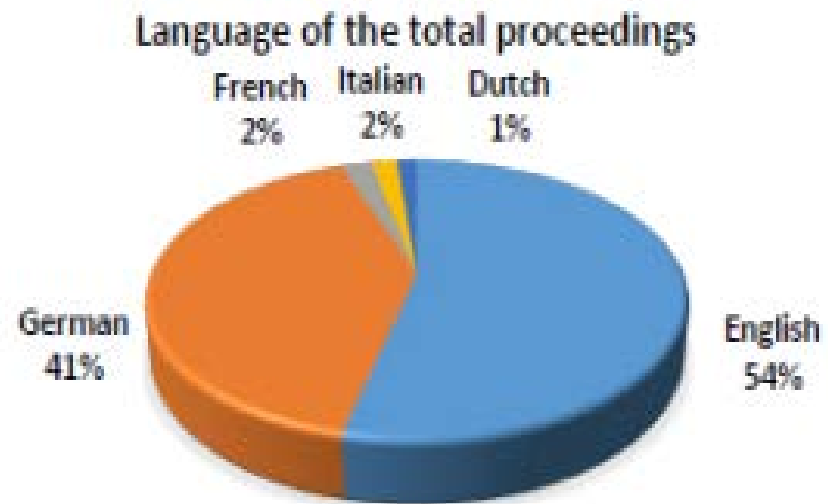

31 August
2024

III. How can an alleged infringer claim invalidity before the UPC?

How can an alleged infringer claim invalidity before the UPC?

- The alleged infringer has **two possibilities** to claim invalidity before the UPC.
- It may either
 - 1) after the patent proprietor has brought **an action for infringement of the patent** before a Local or Regional Division or (in exceptional cases) before the Central Division, bring **a counterclaim for revocation** before the same Division, or
 - 2) bring right away **an action for revocation of the patent** before the Central Division of the UPC Court of First Instance.

Composition of panels

- An infringement action with counterclaim for revocation is decided in a Local or Regional Division by a panel of 3 legally qualified judges and 1 technically qualified judge.

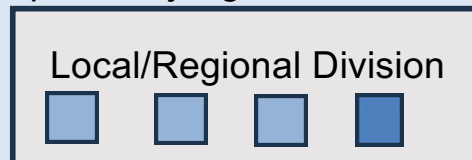

- An action for revocation is decided in the Central Division by a panel of 2 legally qualified judges and 1 technically qualified judge.



Stages of proceedings of an infringement action with counterclaim for revocation

Stages of proceedings of an infringement action with counterclaim for revocation

1) Written procedure

- Exchange of written pleadings
 - infringement action
 - defence counterclaim for revocation
 - reply defence amendment of patent
 - Rejoinder reply defence
 - rejoinder reply
 - rejoinder
- Deadlines apply to all statements.

Stages of proceedings of an infringement action with counterclaim for revocation

2) Interim procedure

- Preparation of the oral hearing
- Exploration of possibilities to settle the case

3) Oral procedure

- Preliminary introduction to the case by the judges possible
- Pleadings of the parties
 - Time limits may be set in advance
- Hearing of witnesses and experts. Judges and parties may put questions.
- Endeavour to complete the oral hearing in one day.

4) Decision on the counterclaim for revocation/action for revocation

- Total revocation of the patent
 - with *erga omnes* effect
 - in the Contracting Member States in which the patent has been validated.
- Partial revocation of the patent (upon request of amendment)
 - with *erga omnes* effect
 - in the Contracting Member States in which the patent has been validated
- Rejection of the counterclaim/action for revocation.

IV. Recent developments in patent disputes before the UPC

Recent developments in patent disputes before the UPC

- The UPC is up and running since 1 June 2023.
- **389 cases have been filed in the Court of First Instance** as of 30 September 2024, including
 - 192 actions for infringement
 - 103 counterclaims for revocation
 - 45 actions for revocation
 - 49 actions for preliminary injunction, preservation of evidence and inspection
- **96 appeals, mainly procedural appeals but also appeals in preliminary injunction and preservation of evidence cases, have been filed in the Court of Appeal** as of 30 September 2024

- Court of Appeal order of 26 February 2024 - NanoString/10x Genomics
 - **Interpretation of patent claims**
 - The patent claim is the decisive basis for determining the protective scope of the patent.
 - Description and drawings must always be used as an explanatory aid.
 - The patent has to be interpreted from the point of view of a person skilled in the art.
 - These principles apply to the assessment of an infringement and the legal validity of a patent alike.

- **Obviousness**

- It can be a **starting point for the assessment of obviousness** that a piece of prior art would have been of interest to the person skilled in the art (psa) who, at the priority date of the patent, was seeking to find a solution of the problem underlying the patent.
- In UPC CoA, 26 Feb. 2024 - NanoString/10x Genomics, it was the assumption that one of the pieces of prior art “D6”, put forward by the defendant, would have been of interest to the psa who at the priority date of the patent at issue, was seeking to develop high-throughput optical multiplexing methods for detecting target molecules in a sample.

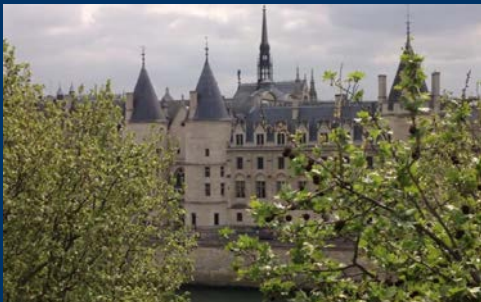

Thank you for your attention



Part I: Presentations from Judges

- i. Remark: Presiding Judge Shimizu (Japan)
- ii. Dr. Grabinski (UPC)
- iii. **Mr. Justice Mellor (UK)**
- iv. Federal Judge Choe-Groves (USA)

Panel Discussion

Mr Justice James Mellor

My background

- Studied Engineering & Production Engineering at King's College, Cambridge - before, during and after University, worked in industry in UK, France, Germany, Somalia, the Congo & Iraq.
 - 1 year conversion course studying law (also at King's, Cambridge)
 - 1 year Bar School, 1 year pupillage.
 - Practised as a barrister (Chambers of Robin Jacob/Hugh Laddie) 1987-2021, QC in 2008.
 - Full range of IP&IT litigation – Patents, Copyright, Trade Marks, Confidential Information, Designs, Technical Contractual Disputes. Several references to the CJEU & cases in the GCt
-

Judge of the Chancery Division since February 2021

One of two Category 4 & 5 Patents Judges (with Mr Justice Meade)

We spend most of our time in trials of the most technically complex patent cases – mobile phones, pharmaceuticals, biosimilars, medical devices, mechanical inventions etc.

Plus FRAND rate determinations, often global (e.g. *InterDigital v Lenovo* (2023), *Panasonic v Xiaomi* (current))

In the UK Patents Court, we try any case involving patents, along with all other issues – inventorship disputes, patent license disputes, competition defences etc.

Inventive Step / Obviousness

s.3 Patents Act:

“An invention shall be taken to involve an inventive step if it is not obvious to a person skilled in the art, having regard to any matter which forms part of the state of the art”

The Court frequently applies a structured test from the *Pozzoli* case – summarised as follows:

- 1) Identify skilled person + CGK**
- 2) Identify inventive concept of the claim of the Patent**
- 3) Identify differences between the prior art and the inventive concept of the Patent**
- 4) Without hindsight, were the differences obvious to the skilled person at the priority date in light of the CGK?**

Claims of Invalidity – Rules and Practices (1)

The Rules (based on many years of experience) are set out in the Civil Procedure Rules Part 63 (Intellectual Property Claims) rule 63.6, as supplemented in the Part 63 Practice Direction.

A Claim of Invalidity:

- **Can be brought as a claim for revocation (Claimant seeking to clear away the Patent), although the patentee often counterclaims for infringement.**
- **Or as a counterclaim to an infringement claim.**

The Statement of Case must [CPR Part 63 Practice Direction para 4.2 (1) & (2)]:

- **Contain particulars of the remedy sought and of the issues *except* those relating to validity of the patent**
- **Have a separate document attached headed ‘Grounds of Invalidity’**

Claims of Invalidity – Rules and Practices (2)

The Grounds of Invalidity must [CPR Part 63 Practice Direction para 4.2(2):

- (a) Specify the grounds on which validity of the patent....is challenged; and**
- (b) Include **particulars** that will clearly define every issue (including any challenge to any claimed priority date) which it is intended to raise; and**
- (c) A copy of each document referred to in the Grounds of Invalidity, and where necessary a translation of the document, must be served with the Grounds of Invalidity.**

Furthermore:

Para 4.3(1): If challenged for lack of novelty or lack of inventive step, the **particulars must specify details of the matter in the state of the art relied on, as set out in para 4.4**

Para 4.4(1): if in a document, the date on which and the means by which it was made available to the public.

Claims of Invalidity – Rules and Practices (3)

And

Para 4.3(2): If **insufficiency** is alleged, the **particulars** must state, if appropriate, which examples of the invention cannot be made to work and in which respects they do not work or do not work as described in the specification

Para 4.4(2): If a **prior use** is alleged, the details required are (a) the date or dates of such use, (b) the name of all persons making the use, (c) the place of the use, (d) any written material which identifies the use, (e) the existence and location of any **apparatus** employed in such use and (f) all facts and matters relied on to establish that such matter was made available to the public.

Para 4.5: the Court may order inspection of any **apparatus** or machinery

Para 4.6: if commercial success is relied upon (against an allegation of obviousness), the grounds of it must be set out in the statement of case.

Claims of Invalidity – Rules and Practices (4)

The Rules in **CPR 63 PD** are the **minimum** requirements.

Frequently, parties will be ordered to exchange **additional statements of case on specific issues**, and these may comprise claim charts, divided into the integers of each claim.

For example:

Novelty: which passages in a long document are relied upon, against each integer of the claim

Inventive step: which integers of the claim are disclosed in each piece of prior art

[cf similarly with infringement:

On a normal construction: what is said, in the alleged infringement, to satisfy each integer of the claim

On equivalents: which features are said to be equivalent (and why) – *Facebook v Voxer*

My Recent Judgments – the pattern of work

InterDigital v Lenovo [2023] EWHC 172 (Pat). Trial C. Sending of Scheduling Information in HSUPA

InterDigital v Lenovo [2023] EWHC 538 & 539 (Pat). Trial E. FRAND trial setting a global rate for 2007-end2023.

Astellas v Teva [2023] EWHC 2571 (Pat). Modified release formulation of mirabegron

[Lifestyle Equities v RCB Polo Club [2023] EWHC 2923 (Ch). Dispute between 2 ‘polo’ brands]

Abbott v Dexcom [2024] EWHC 36 (Pat). Trial A. 4 patents. Glucose monitoring devices

[COPA v Wright [2024] EWHC 1198 (Ch). Was Dr Craig Wright ‘Satoshi Nakamoto’, the inventor of Bitcoin?]

Abbott v Dexcom [2024] EWHC 1664 (Pat) Trial B. 1 patent. Glucose monitoring devices.

Pfizer v GSK [2024] EWHC 2523 (Pat). Vaccine for Respiratory Syncytial Virus.

Accord v Astellas [2024] EWHC 2524 (Pat). Whether a patent for enzalutamide was obvious over some very close prior art.

Sandoz v Biogen [2024] EWHC 2567 (Pat). Method of assessing risk of Progressive Multifocal Leukoencephalopathy in Multiple Sclerosis patients treated with natalizumab



Part I: Presentations from Judges

- i. Remark: Presiding Judge Shimizu (Japan)**
- ii. Dr. Grabinski (UPC)**
- iii. Mr. Justice Mellor (UK)**
- iv. Federal Judge Choe-Groves (USA)**



INTERNATIONAL JUDICIAL SYMPOSIUM ON INTELLECTUAL PROPERTY 2024

The Honorable Jennifer Choe-Groves
U.S. Court of International Trade

OVERVIEW

- Introduction
- Litigation at the Court of International Trade
- Invalidity Under U.S. Patent Law
- Recent Patent Issues

BIOGRAPHY

- Nominated by the President of the United States and confirmed unanimously by the United States Senate in 2016.
- **Education:** Princeton University; Rutgers School of Law-Newark, 1994, J.D.; Columbia Law School, LL.M.
- **Career Record:** Judge Choe-Groves began her professional career serving as a criminal prosecutor in the Manhattan District Attorney's Office. She served in the Executive Office of the President of the United States under President George W. Bush and President Barack Obama as Senior Director for Intellectual Property and Innovation and as Chair of the Special 301 Committee for the Office of the United States Trade Representative (USTR). Prior to her appointment to the United States Court of International Trade, Judge Choe-Groves was in private practice. Her 30-year legal career has focused on international trade, intellectual property, and litigation.



U.S. COURT OF INTERNATIONAL TRADE
NEW YORK, NEW YORK

U.S. COURT OF
INTERNATIONAL
TRADE

- **9 Judges**
- **5 Senior Judges**



UNITED STATES CONSTITUTION

ARTICLE III, SECTION ONE:

The judicial Power of the United States, shall be vested in one supreme Court, and in such inferior Courts as the Congress may from time to time ordain and establish. The Judges, both of the supreme and inferior Courts, shall hold their Offices during good Behaviour, and shall, at stated Times, receive for their Services, a Compensation, which shall not be diminished during their Continuance in Office.



JURISDICTION
OF FEDERAL
COURTS

Requirements:

Cases or Controversies

No Advisory Opinions

Subjects:

- U.S. Constitution
- Federal Law
- Treaties
- Bankruptcy, customs, patent, admiralty, international trade

Party

- Federal or state government, ambassadors, public officials, foreign states

Diversity

- Citizens of different states, if amount is > \$75,000

STRUCTURE OF FEDERAL COURTS

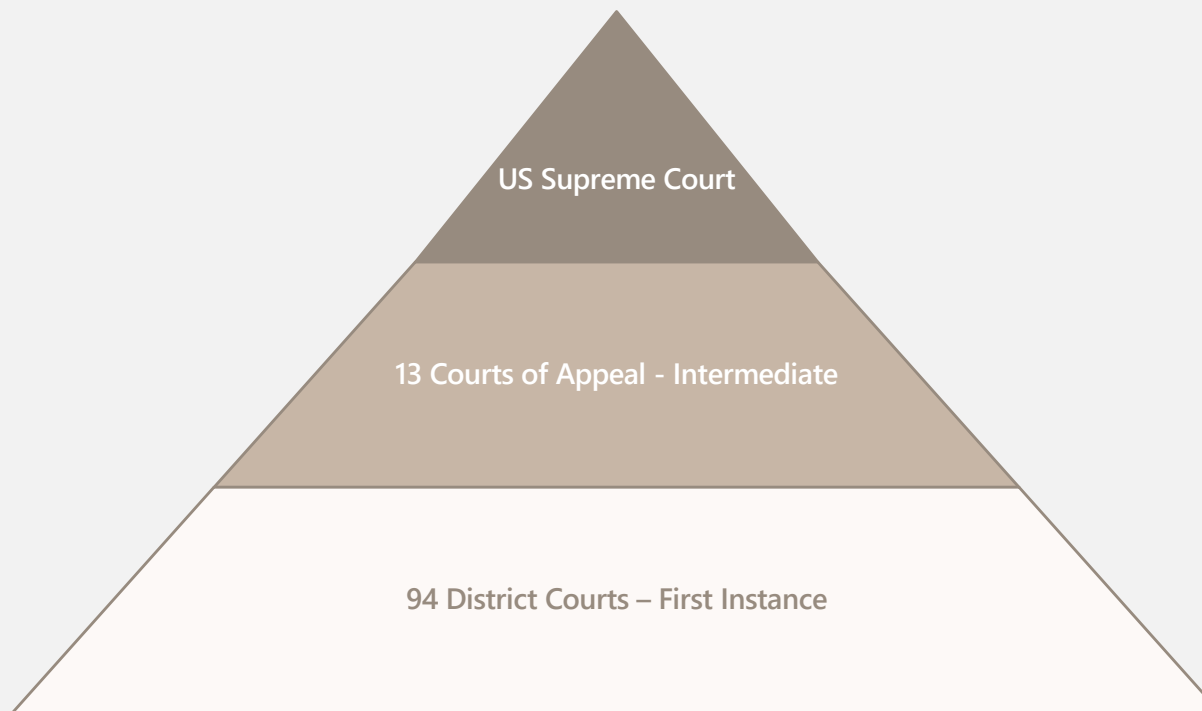

CUSTOMS AND INTERNATIONAL TRADE LITIGATION

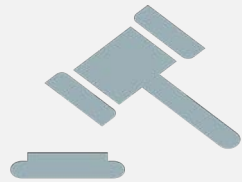

Customs Litigation

Classification

Valuation

Country of Origin

Brokers/Testing Laboratory



Trade Litigation

Antidumping Duties

Countervailing Duties

CUSTOMS AND
INTERNATIONAL
TRADE LITIGATION

Civil Penalties

- Fraud
- Gross Negligence
- Negligence

Liquidated Damages

- Suits on a bond

Collection Action

- Suits for unpaid duties



LITIGATION PROCESS

- Action filed
- Assigned to a single judge - 28 U.S.C. § 254
- In limited circumstances, action assigned to a 3-judge panel for Constitutional issues or significant cases - 28 U.S.C. § 255
- Slip Opinion issued stating reasons and facts upon which the decision is based - 28 U.S.C. § 2645
- Slip Opinion posted on the USCIT website
- Appeal to U.S. Court of Appeals for the Federal Circuit, then to U.S. Supreme Court

INTERNATIONAL
INTELLECTUAL
PROPERTY: CASE
STUDIES

Milecrest Corp v. United States and Duracell, 2017, batteries trademarked by Duracell, authorized for sale outside U.S., unauthorized import into U.S. as “grey market goods” without an IP license. Held: trademark owner could bar import of unauthorized grey market goods into the U.S. by an unlicensed third party.

U.S. Auto Parts Network v. United States, 2018, Customs stopped approximately 100 containers of imported vehicle car parts bearing trademarks. Issue before the court: amount of bond. Previous annual bond \$200,000 for all shipments; in this case Customs imposed a bond of US millions for IP infringing goods (based on 3 times value of shipments).

One World v. United States, 2018, International Trade Commission granted exclusion order to exclude import of patent-infringing garage door openers (“337 Order”). Company designed new product to avoid patent infringement, imported new products that were stopped at the U.S. border by Customs

SITTING BY DESIGNATION AS A VISITING JUDGE

Appointed by the Chief Justice of the U.S. Supreme Court

- U.S. Court of Appeals for the Ninth Circuit
- U.S. Court of Appeals for the Second Circuit
- U.S. District Court for the District of Delaware
- U.S. District Court for the Southern District of New York
- U.S. District Court for the District of Idaho
- U.S. District Court for the District of Arizona
- U.S. District Court for the Northern District of Oklahoma



BRINGING A CLAIM FOR INVALIDITY UNDER U.S. PATENT LAW

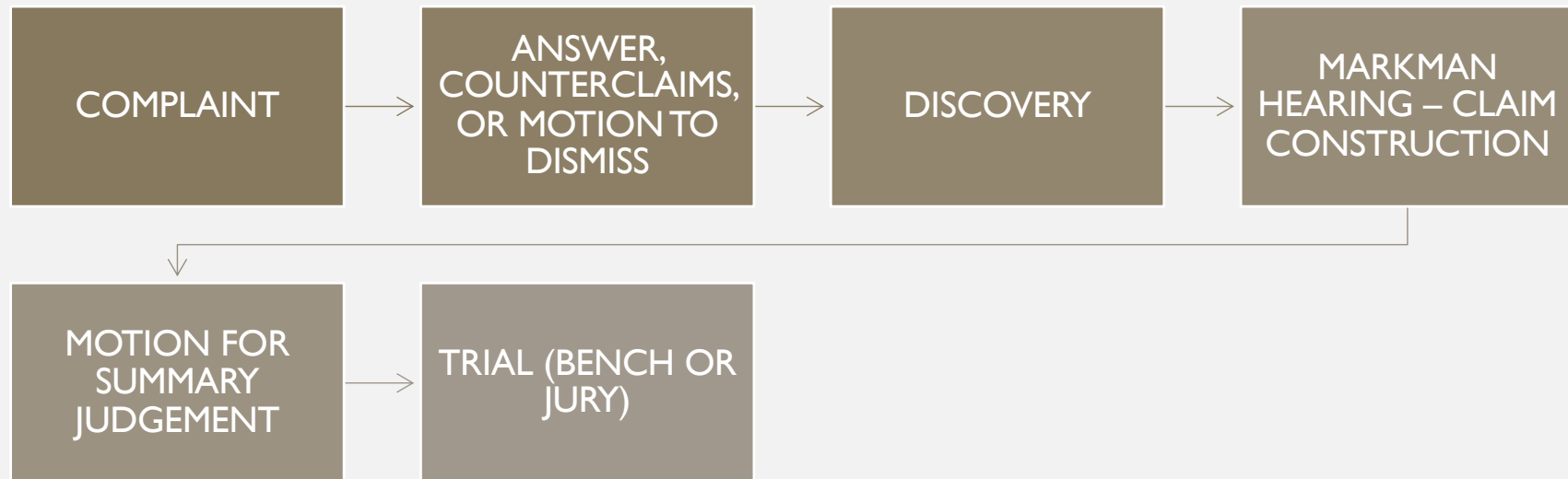

INVALIDITY UNDER U.S. PATENT LAW

- To receive a patent, the inventor must show that their invention is (1) useful; (2) novel; and (3) non-obvious.
- Useful: An invention is considered useful when it has a specific, substantial, and credible utility, and when it can actually perform what it is intended to do.
- Novel: An invention is considered novel when it is not found in prior art, or when the combination of features claimed is not found in a single prior art reference.
- Obviousness: An invention is considered obvious if a skilled practitioner in the relevant field could have easily created it based on prior art.
- 35 U.S.C. §§ 102, 103.

INVALIDITY BASED ON OBVIOUSNESS

A patent may not be obtained “if the differences between the subject matter sought to be patented and the prior art are such that the subject matter as a whole would have been obvious to a person having ordinary skill in the art.” 35 U.S.C. § 103(a).

The Court looks at:

- The *Graham* factors
- Whether a skilled artisan (or a person of ordinary skill in the art (POSA)) would have been motivated to modify or combine disclosures in the prior art

INVALIDITY BASED ON OBVIOUSNESS

Obviousness is a question of law based on underlying facts. See KSR Int'l Co. v. Teleflex Inc., 550 U.S. 398, 427 (2007).

The underlying facts to be found include: (1) the scope and content of the prior art; (2) differences between the prior art and the claims at issue; (3) the level of ordinary skill in the pertinent art; and (4) secondary considerations such as commercial success, long felt but unsolved needs, and failure of others. See Graham v. John Deere Co., 383 U.S. 1, 17–18 (1966).

A determination of obviousness “requires consideration of all four Graham factors, and it is error to reach a conclusion of obviousness until all those factors are considered.” Apple Inc. v. Samsung Elecs. Co., 839 F.3d 1034, 1048 (Fed. Cir. 2016) (en banc). “Objective indicia of nonobviousness must be considered in every case where present.” Id.

INVALIDITY
BASED ON
OBVIOUSNESS

Proving obviousness also requires a showing by **clear and convincing evidence** that the person of ordinary skill in the art (“POSA”) would have had a reasonable expectation of success in achieving the claimed invention. InTouch Techs., Inc. v. VGO Commc’ns, Inc., 751 F.3d 1327, 1347 (Fed. Cir. 2014).

Whether a skilled artisan would have been motivated to modify or combine disclosures in the prior art is a question of fact. See Univ. of Strathclyde v. Clear-Vu Lighting LLC, 17 F.4th 155, 160 (Fed. Cir. 2021).

RECENT PATENT ISSUES

- **Whether Knowledge of the Patents-in-Suit First Obtained from a Complaint May Support a Claim for Post-Filing Indirect Infringement and Willful Infringement**
- The District of Delaware has an intra-circuit split over the issue of whether a defendant's knowledge of a patent and its infringement may be demonstrated through the filing of a complaint alone or amended complaint for post-suit claims for indirect infringement and willful infringement. The United States Supreme Court and the U.S. Court of Appeals for the Federal Circuit have not conclusively settled this question.
- Majority view: Under this view, the filing of a complaint is sufficient notice to meet post-suit knowledge for indirect and/or willful infringement claims. The service of a mooted original complaint acts like "a pre-complaint notice letter" and provides the requisite pre-filing knowledge for willful and induced infringement for a later-filed amended complaint.
- Minority view: Under this view, the filing of a complaint is not sufficient to meet the post-suit knowledge for indirect and/or willful infringement claims.

THIRD PARTY LITIGATION FUNDING (TPLF)

- TPLF is a rapidly growing business practice, especially in patent cases, in which non-parties invest in litigation by paying money to a plaintiff or his/her counsel in exchange for a contingent interest in any proceeds/damages from the lawsuit.
- Mostly occurs in secret, except when a judge requires the disclosure of third party litigation interests to be identified by the parties.
- Estimated that litigation funders had U.S. \$15.2 billion in assets allocated in U.S. litigation in 2023.
- Non-practicing entities ("NPEs"), persons who hold patents only for litigation and do not make or sell any products, filed almost 50% patent cases in the U.S. in the past 20 years.



THANK YOU



Agenda

- I. Presentations from Judges
- II. Reviewing Mock Trials**
- III. Recent Trends: from Attorney's Viewpoint
- IV. Wrap Up

Part II: Reviewing Mock Trials

Courts' Opinions

	Japan	UPC	USA	UK
Validity	✓ Valid	✓ Valid	✓ Valid	✓ Valid
Infringement	✓ Infringes	✓ Infringes	✓ Infringes	✓ Infringes



Part II: Reviewing Mock Trials

- i. **Validity: Inventive Step / Non-obviousness**
- ii. **Claim Construction (if time allows)**

Part II: Reviewing Mock Trials: Validity

Courts' Opinions: Validity

	Japan	UPC	USA	UK
Validity	<p>✓ Valid</p> <p>There is an inhibiting factor (teaching-away) to replace PA's flap with flap with protrusion.</p>	<p>✓ Valid</p> <p>It was not obvious for a psa who was supposed to solve the problem underlying the invention to come up with a solution including element F.</p>	<p>✓ Valid</p> <p>The Invention was not obvious</p>	<p>✓ Valid</p> <p>It would not have been obvious to alter PA arrangement of flap & hole. Counterintuitive to throw away the automatic operation of flap & hole.</p>

Part II: Reviewing Mock Trials: Validity

Japan

1. Find the gist of the Invention
2. Find the near(est) Prior Art
3. Identify differences between 1 & 2
4. Examine whether a person skilled in the art, from the Prior Art, would have easily arrived at the Invention
 - ✓ Teaching/Suggestion in PA
 - ✓ Relevance of technical fields
 - ✓ Common problem/function
 - ✓ Motivation to combine existing Art / or “Teaching-away”
 - ✓ Unexpected effect, etc.



Part II: Reviewing Mock Trials: Validity

UPC

Person skilled in the art

Problem to be solved

Prior art of interest

Different technical functions of the flap in the prior art

No pointer to the claimed invention

Part II: Reviewing Mock Trials: Validity

UPC

- **Starting point** for such a psa would be a storage container with a lid as known in the prior art and shown in Figures 5-8 of the patent specification.
- In such a container food can be heated in a microwave.
- The container comprises a lid with a flap that has a protrusion that can close a through hole in the lid by which excess water can be removed.
- The flap is arranged below the through hole at an outer periphery of the lid.
- The configuration known in the prior art **results in the problem** that the water drained from the through hole, when it is not closed by the flap, hits the flap and splatters.

Part II: Reviewing Mock Trials: Validity

UPC

- For the psa, trying to solve this problem, the US patent application 2006/0077XX would be of interest as it also concerns
 - a storage container with a lid
 - made of plastic with a heat-resistant temperature range of -40 to 100° C.
 - so that frozen food in the storage container can be defrosted in a microwave oven and
 - **the lid is provided with a flap and a through hole outside a base end portion of the flap.**

Part II: Reviewing Mock Trials: Validity

UPC

- However, the flap
 - does not have a protrusion that allows to close or open the through hole depending on whether excessive water is to be removed from the container.
- **The function of the flap** disclosed in the US patent application is **rather that of a non-return valve** after vacuuming the container through the through hole by a vacuum pump
 - as the flap is pressed to an annular area around the through hole when the pressure inside is lower than the pressure outside the storage container.



Part II: Reviewing Mock Trials: Validity

UPC

- In view of **this different functional context**, the psa **had no reason to consider** the position of the flap as disclosed in the US patent application to solve his problem of preventing excess water draining from the open through hole from hitting the flap and splatting.
- It follows that it was not obvious for a psa who was supposed to solve the problem underlying the invention to come up with a solution including element F of claim 1 of the patent-in-suit.

Part II: Reviewing Mock Trials: Validity

UPC

Problem-Solution Approach (from EPO website)

In order to assess inventive step in an objective and predictable manner, the so-called "problem-solution approach" is applied. In the problem-solution approach, there are three main stages:

- i. determining the "closest prior art",
- ii. establishing the "objective technical problem" to be solved, and
- iii. considering whether or not the claimed invention, starting from the closest prior art and the objective technical problem, would have been obvious to the skilled person.

NanoString Tech. v. 10x Genomics, Inc. (UPC_CoA_335/2023 issued on 26/02/2024)



Part II: Reviewing Mock Trials: Validity

USA

Graham factors (*Graham v. John Deere Co.*, 383 U.S. 1 (1966))

- i. the scope and content of the prior art
- ii. the level of skill of a person of ordinary skill in the art
- iii. the differences between the claimed invention and the teachings of the prior art
- iv. the extent of any objective indicia of non-obviousness

TSM test (*Alza Corp. v. Mylan Labs., Inc.*, 464 F.3d 1286 (Fed. Cir. 2006))

When a claim of obviousness is made based on multiple pieces of prior art, the TSM test requires **some teaching, suggestion, or motivation** that would have led a person of ordinary skill in the art to combine the prior art references in the matter claimed in the patent.

KSR (*KSR Int'l Co. v. Teleflex Inc.*, 550 U.S. 398 (2007))

“The obviousness analysis cannot be confined by a formalistic conception of the words teaching, suggestion, and motivation, or by overemphasis on the importance of published articles and the explicit content of issued patents.”

Part II: Reviewing Mock Trials: Validity

USA

USPTO: Updated guidance for determining obviousness

(89 Fed. Reg. 14449 (Feb.27, 2024))

A. Flexible approach to understanding the scope of prior art

“the Supreme Court instructed the Federal Circuit that persons having ordinary skill in the art (PHOSITAs) also have common sense, which may be used to glean suggestions from the prior art that go beyond the primary purpose for which the prior art was produced.” *Id.* at 14450. (emphasis added)

B. Flexible approach to providing a reason to modify the prior art

“numerous possible sources . . . provide reasons to combine or modify the prior art These include “market forces; design incentives; the ‘interrelated teachings of multiple patents’; ‘any need or problem known in the field of endeavor at the time of invention and addressed by the patent’; and the background knowledge, creativity, and common sense of the person of ordinary skill.” *Id.* at 14451. (emphasis added)



Part II: Reviewing Mock Trials: Validity

UK

Pozzoli test (*Pozzoli SPA v BDMO SA* [2007] EWCA Civ 588)

- i. Identifying the skilled person or team and their common general knowledge (CGK)
- ii. Constructing the claim or identifying its inventive concept
- iii. Identifying differences between the claim and the prior art
- iv. Considering whether such differences constitute obvious steps

Other factors to be considered:

- (a) whether the invention was “*obvious to try*”
- (b) the established practices in the field
- (c) the burden and cost of research
- (d) whether the skilled person would need to make value judgments
- (e) whether multiple different pathways of research existed
- (f) the motivations of the skilled person
- (g) whether the results of testing by the skilled person were surprising



Part II: Reviewing Mock Trials: Validity

UK

Validity:

Step (1): skilled person & CGK identified

Step (2): the inventive concept:

Step (3): differences: (1) defrosting/heating; (2) protrusion to close the through hole

Step (4): without knowledge of the Patent, was it obvious for the skilled person to move from the starting point in the prior art to something which falls within claim 1?

- (1) It would have been obvious to apply the prior art arrangement for heating food.**
- (2) It would not have been obvious to alter the prior art arrangement of flap and hole. It would be counterintuitive to throw away the automatic operation of the flap and hole in favour of a CGK arrangement of hole and stopper (protrusion)**

Patent held valid

(cited from UK Mock Trial Slides)



Part II: Reviewing Mock Trials: Validity

UK

Accord, Sandoz & Teva v. Astellas ([2024] EWHC 2524 (Pat). 7 October 2024)

Mr Justice Mellor:

“In some cases, it is helpful to answer this question by adopting the structured approach set out in *Pozzoli*. In other cases, it is helpful to adopt **the problem/solution approach** (PSA) favoured by the EPO. **But neither approach can replace the statutory question itself. It must be assessed by reference to the facts and circumstances of the case.**” [para.180]

Part II: Reviewing Mock Trials: Validity

Prior Art 1 (US7XX)

Embodiment of the Invention

Difference

(1)
Defrost v. Heat

(2)
“Protrusion”

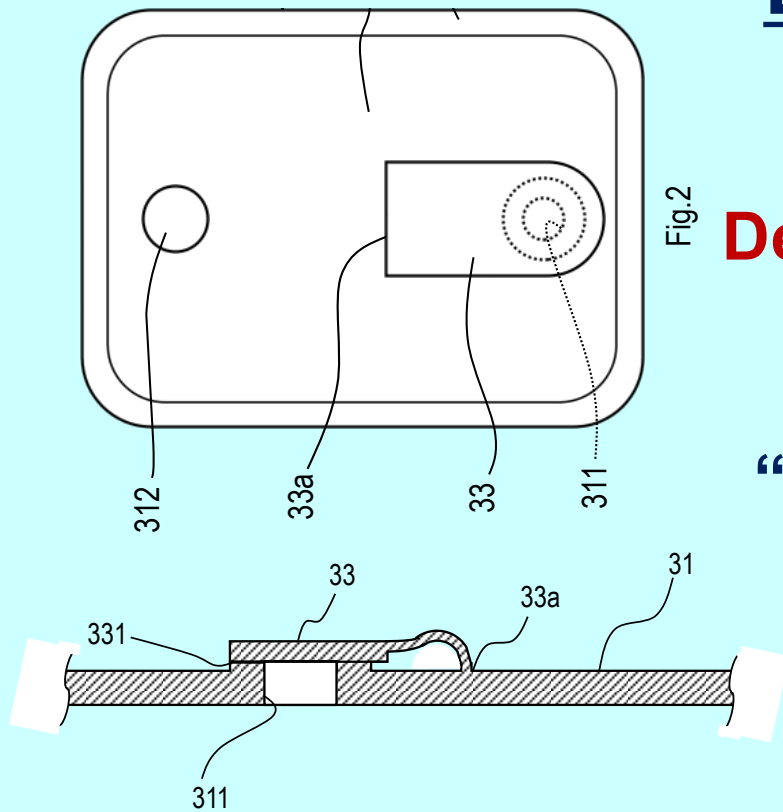

Fig.4A

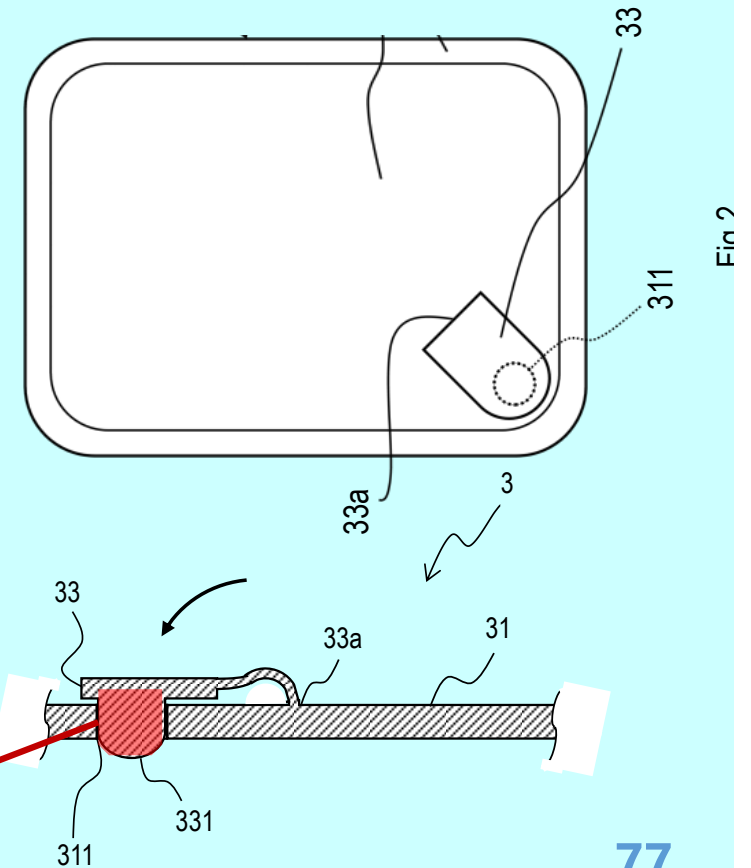
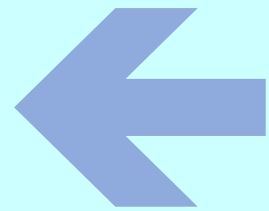
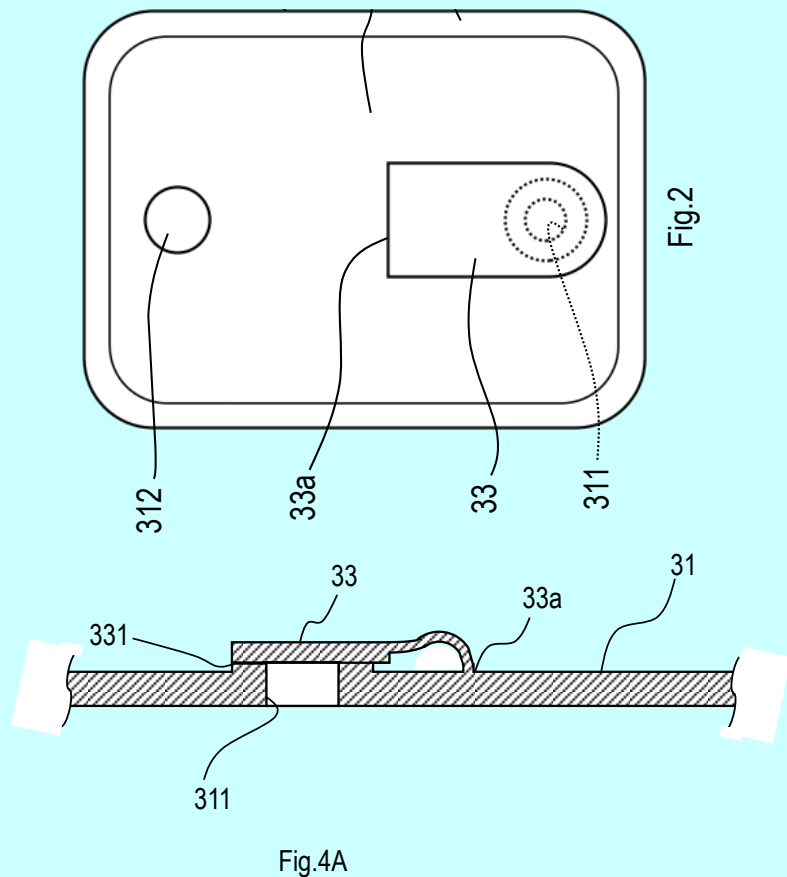

Fig.3B

Part II: Reviewing Mock Trials: Validity

Prior Art 1 (US7XX)



Apply?

Well-known Art (flap w/ protrusion)

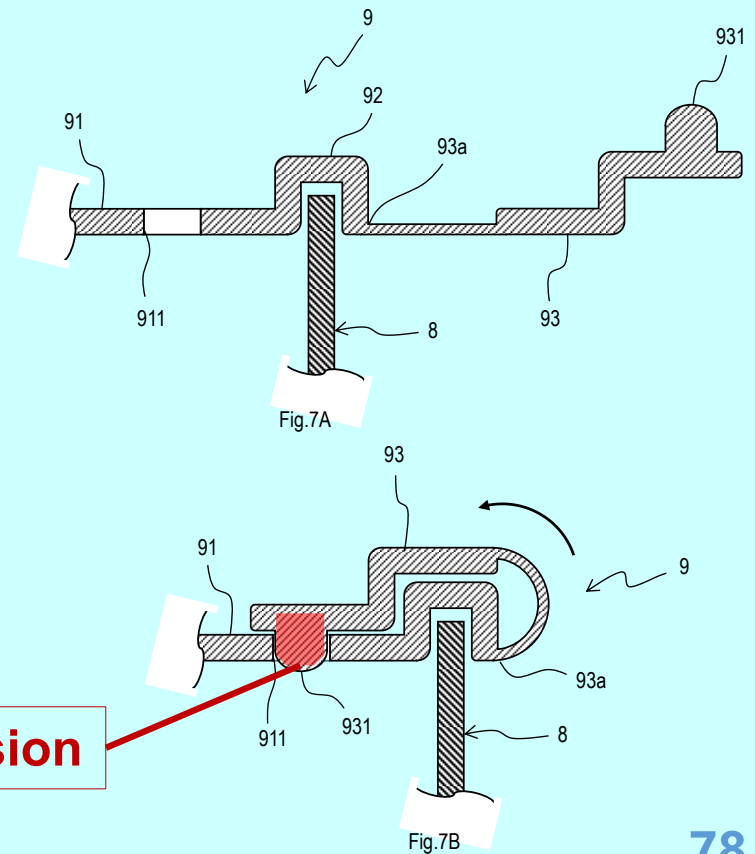

Part II: Reviewing Mock Trials: Validity

Mechanism of Prior Art 1 (US7XX)

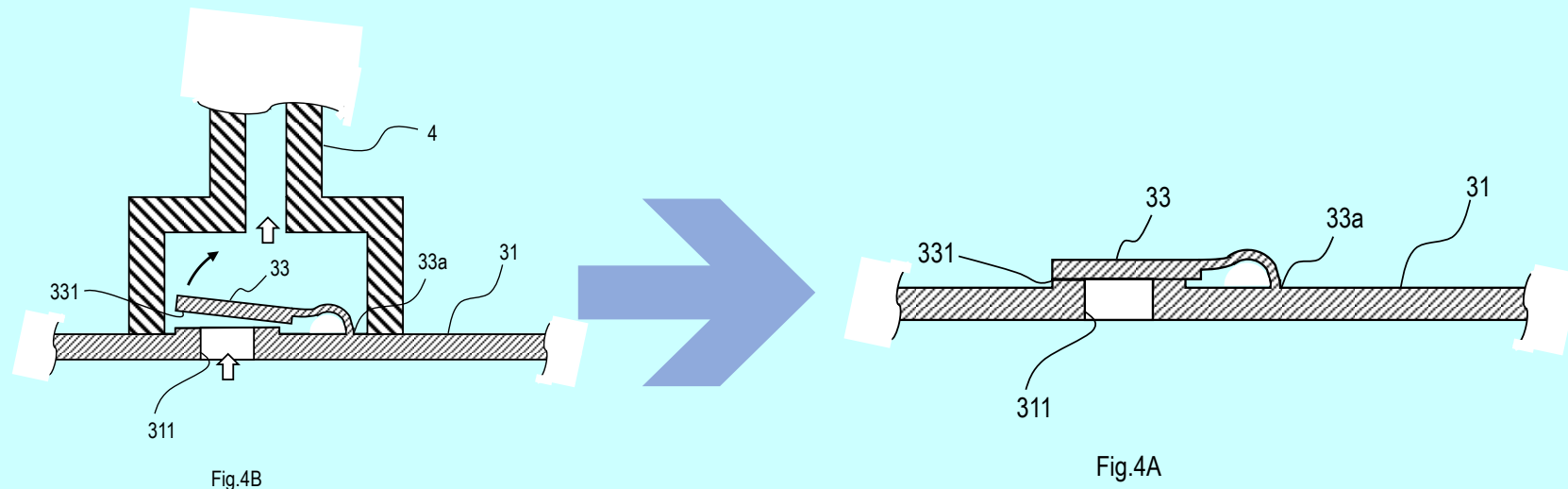

**While vacuuming air,
the flap opens up**

**When stop vacuuming,
the flap automatically closes. By the
difference of pressure, it seals the through
hole tightly to prevent air-leak.**

Part II: Reviewing Mock Trials: Validity

If apply “flap w/ protrusion” to Prior Art 1...

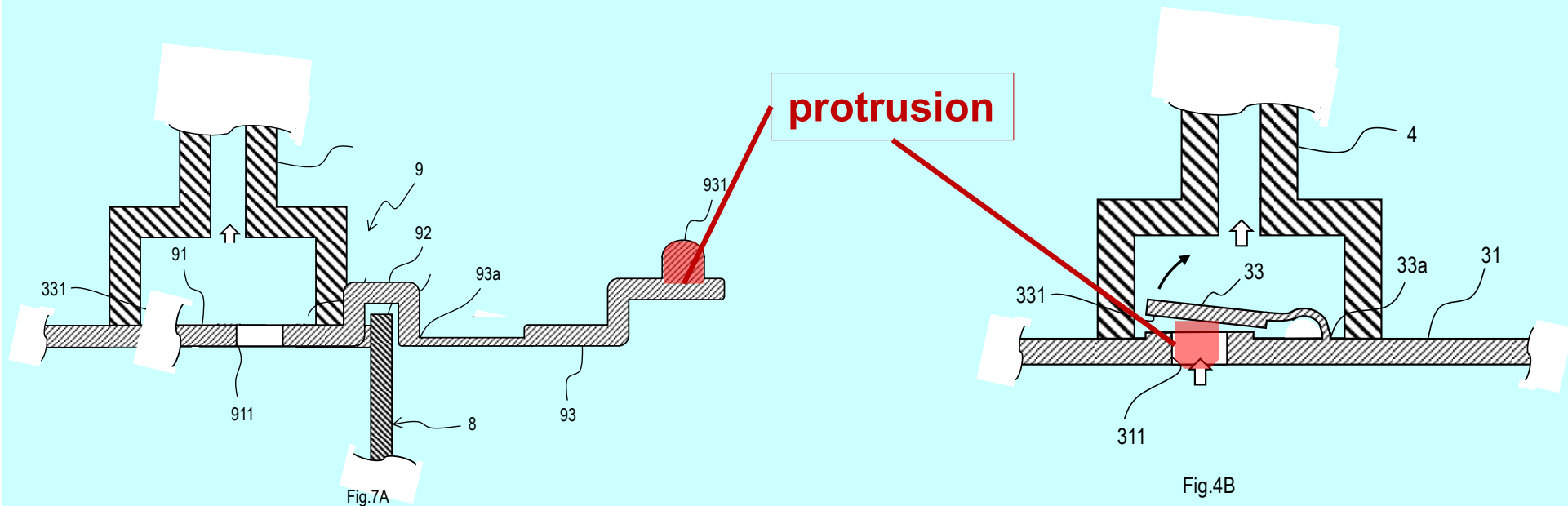

Wouldn't flap w/ protrusion be an obstacle to vacuuming air or auto-closure?

Isn't it a “teach away?”

Part II: Reviewing Mock Trials: Validity

Applicant Admitted Prior Art (AAPA)

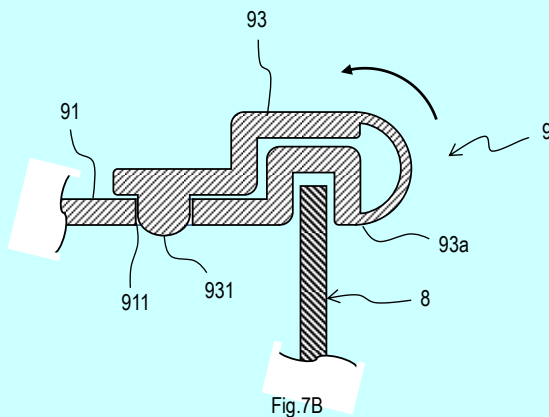
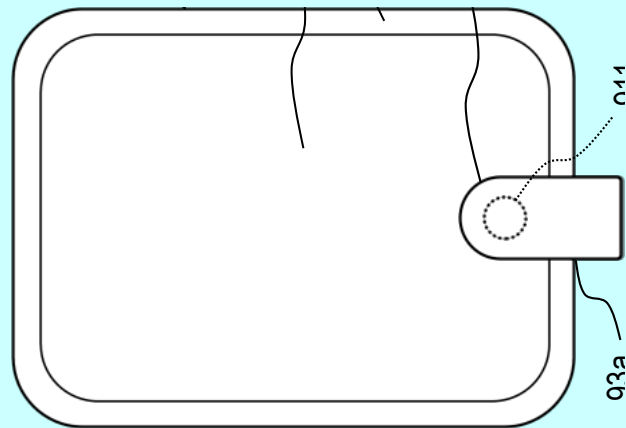

Difference

Relative location of
“flap” and
“through hole”

“**Inside-out**” or “**Outside-in**”

Embodiment of the Invention

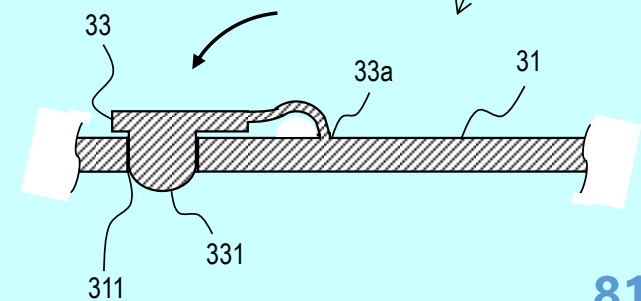
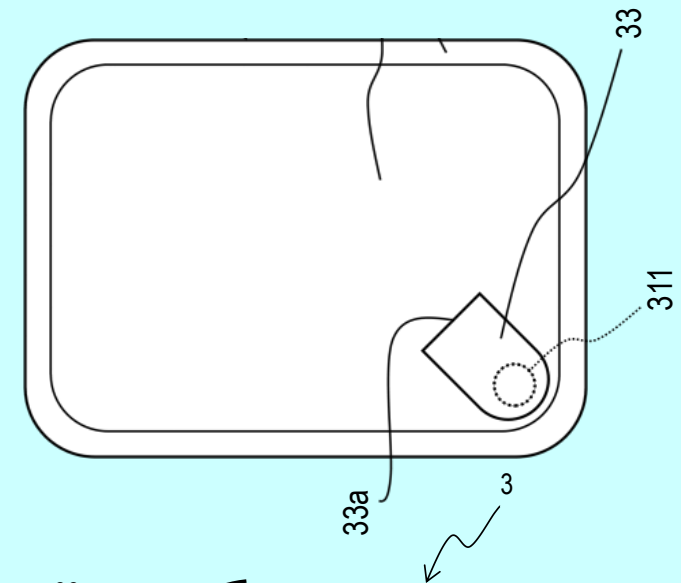
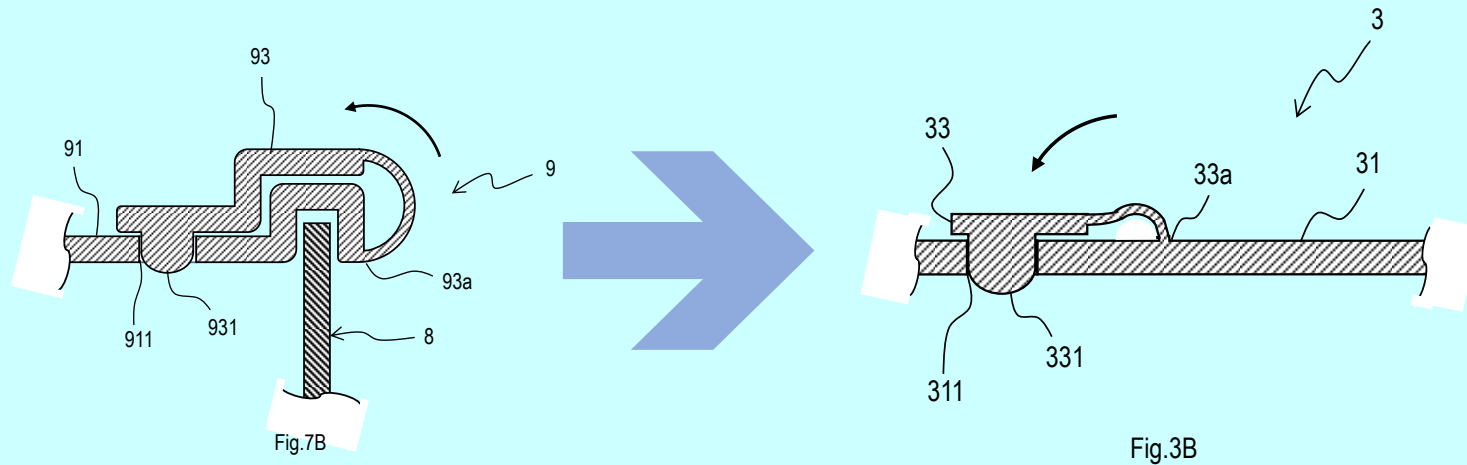

Fig.3B

Part II: Reviewing Mock Trials: Validity

Isn't it a mere **“design change?”**



What about if **“design change”**
adds technical advance?

Part II: Reviewing Mock Trials: Validity

How do you evaluate **“Problem to be solved?”**

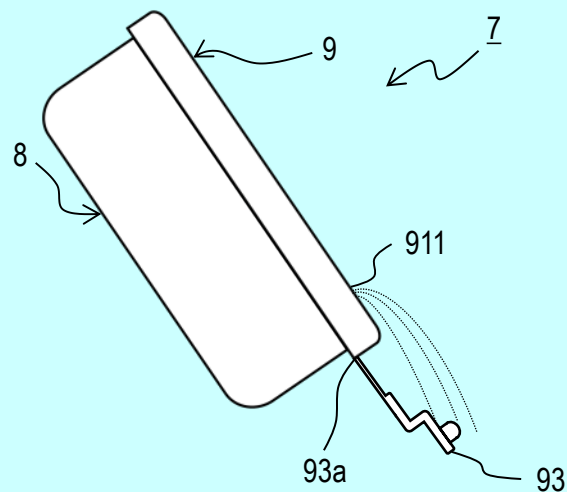

Fig.8

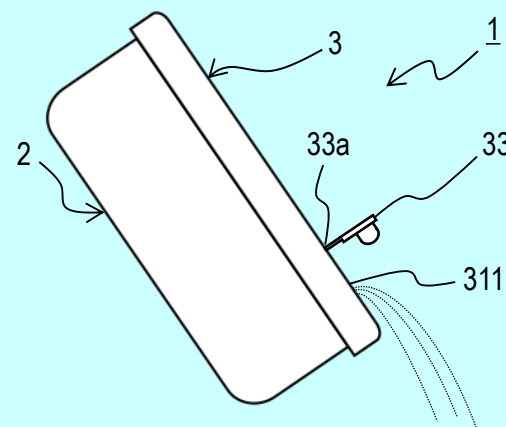
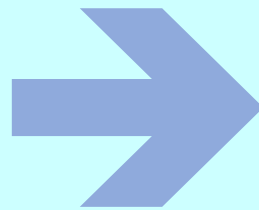

Fig.4

By **“design change,”** it solves the problem of **“splattering”**

Is it mere a **“Minor Problem?”**

Part II: Reviewing Mock Trials: Validity

What about if it has achieved **Commercial Success** by its “splatter-free” function?



©NEIGHBOR CLOWN “Renge de Pasta”
(from Amazon.co.jp website)



Part II: Reviewing Mock Trials

- i. **Validity: Inventive Step / Non-obviousness**
- ii. **Claim Construction (if time allows)**

Part II: Reviewing Mock Trials: Infringem't

Courts' Opinions: Infringement

	Japan	UPC	USA	UK
Infringement	✓ Infringes D's product has a "through hole"	✓ Infringes D's product has a "through hole"	✓ Infringes D's product has a "through hole"	✓ Infringes D's product has a "through hole"

Part II: Reviewing Mock Trials: Infringem't

There's no requirement (i.e. size, shape) regarding
“through hole”



But what about if the
accused product takes
10 minutes to drain
100mL of water, instead
of 60 seconds?

©Alicja Ziaj
(https://unsplash.com/@alicja_photos)



Agenda

- I. Presentations from Judges
- II. Reviewing Mock Trials
- III. Recent Trends: from Attorney's Viewpoint**
- IV. Wrap Up

Part III: Recent Trends – Attorney’s View

Question to Mr. Augenstein (Germany, UPC)

What are your thoughts on the pros and cons of filing a case before UPC? How do you advocate UP or UPC to Japanese companies? Are there any trends in UPC practices Japanese companies should pay attention to as a would-be defendant? (subject to change)



Part III: Recent Trends – Attorney’s View

Question to Ms. Butler (England & Wales)

Could you describe the purposes and merits of preparing a statement of agreed Common General Knowledge (CGK)? Could you also introduce some distinctive features of English Patents Court practices compared to the other jurisdictions? (subject to change)



Part III: Recent Trends – Attorney's View

Question to Mr. Albagli (United States)

Is patentability a hotter issue in US practices rather than obviousness?

Is there any advice for Japanese-based international companies regarding current patent practices in the US, both in prosecution and litigation? (subject to change)



Part III: Recent Trends – Attorney’s View

Question to Mr. Hattori (JAPAN)

How did you feel, as a Japanese practitioner, about today's symposium? Could you introduce the present Japanese practice regarding 1) use of technical experts, 2) progress of court hearings, and 3) evidence collection procedures, in patent infringement litigations? (Subject to change)



Agenda

- I. Presentations from Judges
- II. Reviewing Mock Trials
- III. Recent Trends: from Attorney's Viewpoint
- IV. Wrap Up**



Part IV: Wrap Up – Past, Now, and Future

Question to Dr. Grabinski (UPC)

Based on your long and wide experience, how do you see the future of UPC and international IP litigations? How should judges, litigators, and practitioners be in this rapidly-changing world? (Subject to change)

Part IV: Wrap Up – Past, Now, and Future

Question to Mr. Justice Mellor (United Kingdom)

You have much experience on international patent disputes such as SEP litigations or mega pharmaceutical disputes. How do you see international patent disputes right now and how do you foresee the future? How should we be to overcome the difficulty of global IP disputes? (Subject to change)



Part IV: Wrap Up – Past, Now, and Future

Question to Federal Judge Choe-Groves (United States)

You are in charge of adjudicating international trade disputes as well as patent suits. Do you recognize any trends in disputes on international trades? What should we have in mind when handling international disputes? (Subject to change)

Part IV: Wrap Up – Past, Now, and Future

Question to Presiding Judge Shimizu (Japan)

What do you think the meaning for Japanese practitioners to meet and communicate with judges, litigators and practitioners around the world?
(Subject to change)



That's it.

This is the end of Panel Discussion Program.

See You Tomorrow: JPO Part

And See You Again at JSIP2025 Tokyo!

Sincere Gratitude from IP High Court of Japan